

## Use of High Strength Structural Bolting Assemblies for Preloading BS EN 14399-3 PC 10.9 with Direct Tension Indicators (DTI's)

### **Assembly Configuration**

The standard assembly configuration for BS EN 14399-3 property class 10.9 shall consist of a the following:-

- a) BS EN 14399-3 property class 10.9 bolt (marked 10.9 HR) hot dip galvanized
- b) BS EN 14399-6 hardened chamfered washer (marked H) hot dip galvanized  
(component identified as 4 below)
- c) Direct tension indicator (marked 10.9) mechanically galvanized  
(component identified as 1 below)
- d) Nut face washer (marked HN) sherardized / mechanically galvanized  
(component identified as 2 below)
- e) BS EN 14399-3 property class 10 nut (marked 10 HR) hot dip galvanized

The components shall be assembled as shown below with the hardened chamfered washer fitted under the bolt head with the chamfered face of the washer in contact with the under side of the bolt head.

Note: The washers have a chamfer on the inside diameter with a corresponding chamfer (on the same side of the washer) on the outside diameter.

The bolt and washer are placed in the steelwork and at the other side of the connection the direct tension indicator is fitted with the flat side against the steelwork and the indicator protrusions facing outwards. The nut face washer is placed on top of the indicator protrusions and the nut is assembled with the side containing the marking facing outwards and the smooth unmarked side of the nut against the nut face washer.

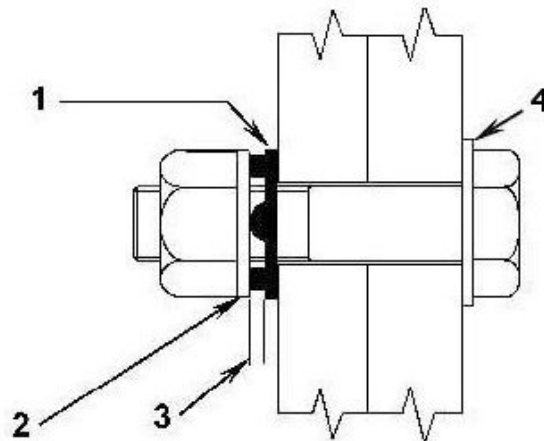

**KEY** 1 Direct Tension Indicator  
2 Nut face washer  
3 Gap  
4 Washer according to EN 14399-6

### **Assembly configuration for EN 14399-3 Property Class 10.9 with DTI Tightened by nut rotation**



## Use of High Strength Structural Bolting Assemblies for Preloading BS EN 14399-3 PC 10.9 with Direct Tension Indicators (DTI's)

### **Initial Tightening**

The bolt head shall be prevented from rotation and each assembly shall be brought to 'snug tight' condition by nut rotation. The tightening process shall be carried out from bolt to bolt within the group, starting from the most rigid part of the connection and moving progressively towards the least rigid part.

Note: The most rigid part of a cover plate connection of an 'I' section is commonly in the middle of the connection bolt group.

The 'snug tight' condition of a fastener assembly shall be when initial deformation of the DTI protrusions begins. This first step shall be completed for all bolts in one connection prior to commencement of the second step.

### **Final Tightening**

When all the assemblies in a connection have been snug tightened then final tightening can commence. Tightening shall be carried out progressively from the most rigid part of the connection to the least rigid part. Tightening shall continue until the specified indicator gap has been achieved (see Table 1)

<b>Table 1</b>	
<b>Thickness of feeler gauge</b>	
Direct tension indicator position	Thickness of feeler gauge
Under nut, when nut is rotated (Figure 1)	0.25mm

The average specified indicator gap shall be determined using the following measurement procedure; the feeler gauge shall be used as a 'no go' inspection tool. The feeler gauge shall be pointed at the centre of the bolt see Figure 2 and shall refuse to enter the number of refusal spaces specified in Table 2. It is advisable to leave some small gap to prevent accidental overtightening and breakage but if the gap has been completely closed inadvertently this is not considered by Cooper & Turner to be cause for rejection.

<b>Table 2</b>	
<b>Feeler gauge requirements</b>	
Number of indicator protrusions	Minimum number of feeler gauge refusals
4	3
5	3
6	4
7	4
8	5
9	5

## Use of High Strength Structural Bolting Assemblies for Preloading BS EN 14399-3 PC 10.9 with Direct Tension Indicators (DTI's)

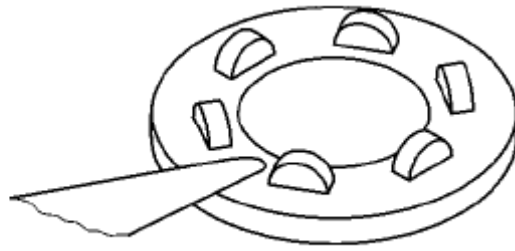

**Figure 2 - Checking the indicator gap (example with six protrusions)**

When the Direct Tension Indicators are installed in accordance with Cooper & Turner's instructions then the shank tension achieved will be in the range shown below.

Nominal bolt diameter	Shank tension kN	
	H10 for 10.9	
	min	max
M16	110	132
M20	172	206
M22 <sup>1</sup>	212	254
M24	247	296
M27 <sup>1</sup>	321	385
M30	393	472
M36	572	688

<sup>1</sup> Non - preferred sizes. Can only be supplied if the quantity required is sufficient to warrant manufacture.